

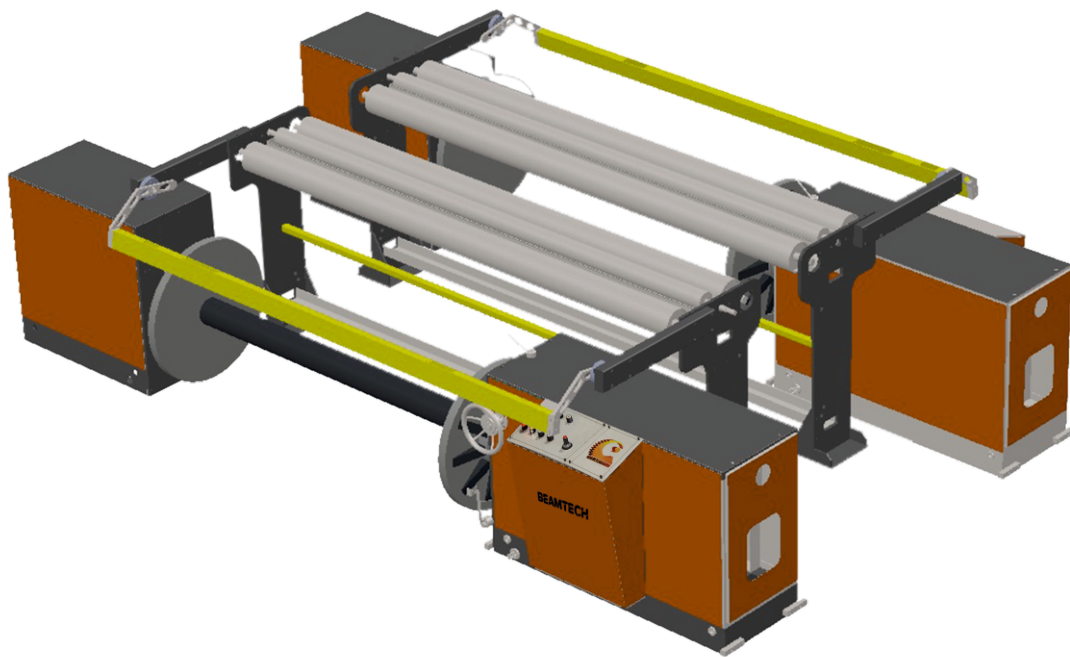

Clartech
Engineers
Private Limited

Definite Technology for
Weaving Preparatory



Beam To Beam Rolling Machine

MODEL : BEAMTECH



Established In
The Year 2004

www.clartechengineers.com



An ISO 9001:2015
Certified Company

Salient Features

- Heavy duty fixed beaming structure on both side.
- Precise length accuracy.
- Adjustable beam arm on both side.
- Direct beaming drive through heavy duty gear box.
- Very much ideal for preparing small lots of same pattern fabrics with several colours in warp sheet.
- Reduction in yarn wastage for small lot sizing.

Technical Specification

DESCRIPTION	SPECIFICATION
WORKING WIDTH	1800 MM TO 4500 MM
BEAM FLANGE DIA.	800 MM TO 1250 MM
MAXIMUM SPEED	150 MTR/MIN
HYDRAULIC BREAK SYSTEM	AIR COLLING SYSTEM
MAXIMUM BEAM TENSION	UP TO 350 KG



Plot-413, "V" Road, Phase-II, GIDC Industrial Estate,
Vatva, Ahmedabad - 382 445. INDIA
Phone: +91 9227778877, +91 9898048636
E-mail: contact@clartechengineers.com
Website: www.clartechengineers.com

Authorised Dealer

